

# 1500-782 STOOL ASSEMBLY GUIDE

PART LEGEND	
<b>A</b>	Upholstered stool head
<b>B</b>	Seat ring & Plywood Anchor
<b>C</b>	Swivel assembly
<b>D</b>	Nut & Washer Assembly
<b>E</b>	Stool column
<b>F</b>	Swivel attachment bolt & washer

## ASSEMBLY INSTRUCTIONS

**1.** Mount column and bell to floor. Set bell in continuous sealant bead around perimeter of bell. Clean excess sealant from floor.

*Note: Remove and replace swivel only as required to access hardware during shipping. Inspect all swivels for secure, tight fit.*

**2.** Position (B) seat ring and plywood anchor over swivel and align stud holes.

**3.** Slide (A) upholstered stool head mounting studs through (B) seat ring, plywood anchor, and (C) swivel assembly.

**4.** Attach (D) nut and washer assembly to (A) mounting studs tighten assembly complete.

*Note: You will need a deep well socket and extension sufficient to reach and tighten nuts from underside*

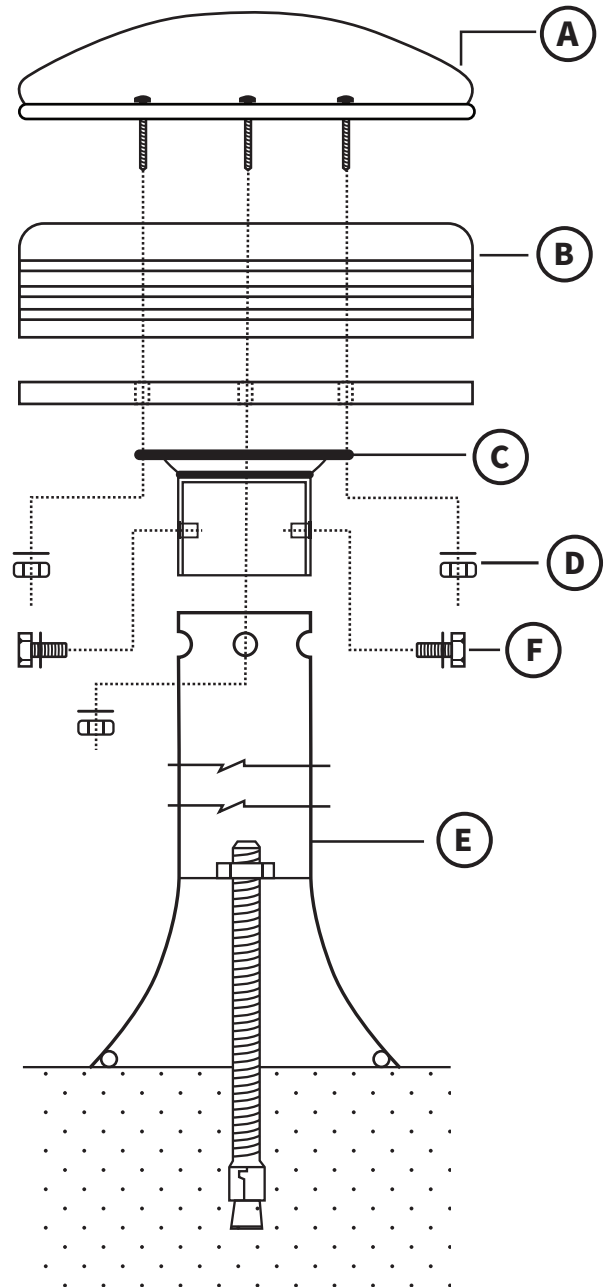

**TYPE-C**